



DLSR3

DLSR3

DSPBRIK™ L-BAND SOFTWARE-DEFINED RADIO, 3RD GENERATION

INPUTS

- Extended L-band analog inputs, 750 MHz to 2150 MHz
- Two or four inputs per 1U chassis
- 4800 MSPS, 14-bit interleaved ADC (ENOB: 8 bits)
- Self-calibration and built-in test capabilities
- Programmable input attenuator (0 dB to 31.5 dB)
- Snapshot, histogram, bit-activity, and overload indicators to easily determine input signal levels
- 1PPS, 10 MHz, IRIG-B, and NTP inputs

PROCESSING

- AMD UltraScale+ MPSoC FPGA with 64-bit processor
- Wideband (4800 MSPS) snapshot capability (up to 5 GB per input)
- Eight digital sub-band tuners (SBTs) per ADC with configurable bandwidths: 80, 40, 20, 10, 5, 2.5 MHz
- Manual and automatic gain controls

OUTPUTS

- Two SFP+ 10-Gigabit Ethernet outputs per analog input
- SDDS packet format, VITA-49 option coming soon
- 8- or 16-bit, real or complex data formats (SI, SB, CB, CI)
- High-precision data time tags provided for DDC and snapshot outputs

CONTROL AND STATUS

- Command and control via embedded-Linux processor
- Front panel LCD interface for easy setup and configuration
- Boot from local flash storage or network file system (NFS)
- Transport Layer Security (TLS)-compliant control interface
- X-Midas option tree and Python API included

DLSR3 BUILDS ON THE DLSR AND DLSR2 LEGACY

- Upgraded digitizing architecture enables continuous frequency coverage from 750 to 2150 MHz and retains wideband snapshot, API, and X-Midas option-tree features—key elements of the DLSR family for over a decade
- Forward-looking DLSR3 design provides new features and capabilities with maximum backward compatibility

DLSR3 USES MULTI-RATE SIGNAL PROCESSING TECHNIQUES

- DLSR3 digitizes multiple L-band inputs with up to eight independent digital sub-band tuner outputs per input
- Tuner data is provided on multiple 10-GbE interfaces for distribution to individual clients or broadcast to multiple recipients
- All outputs include high-precision, high-accuracy time tags supporting the most demanding downstream applications

DLSR3 HAS UNIQUE WIDEBAND SNAPSHOT FEATURE

- Wideband snapshot feature provides continuous surveys of the entire digitized input signal (up to 2150 MHz) to support downlink evaluation and signal discovery
- Snapshot size (up to 5 GB), output rate, and trigger modes are configurable

BLOCK DIAGRAM

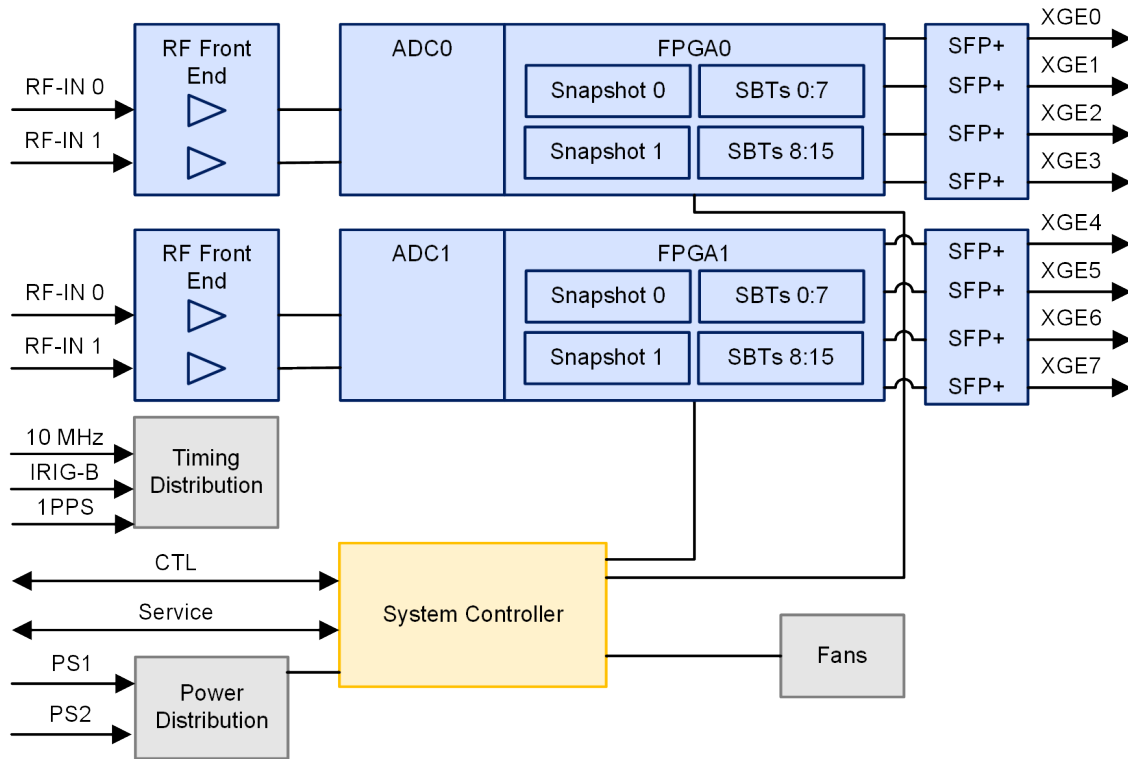

SPECIFICATIONS

GENERAL

- Power connector: IC 60320 C14 with NEMA5-15 cord
- Power: 110/220 VAC 50/60 Hz
- Power consumption: 200W, 2-input, 400 W 4-input, typical
- Number of inputs: Two or four
- Number of 10-GbE outputs: Two per input, maximum of 8
- Dimensions: 1U 19" rackmount, 26" depth
- Operating temperature: 0° C to 50° C

INPUT/OUTPUT LEVELS

- Analog: -35 dBm (nom), 50 Ω, AC-coupled, 500 MHz to 2150 MHz, SMA connector
 - 0 to 31.5 dB input attenuator, 0.5 dB steps
- 10 MHz: 750 mVpp to 2 Vpp (1.5 dBm to 10 dBm) 50 Ω, AC-coupled sine-wave SMA connector
- 1PPS: CMOS compatible, 50 Ω, SMA connector
 - Timecode: IRIG-B: 0.5 Vpp to 6 Vpp, 50 Ω, 1 kHz AM, SMA
- Control: 10/100/1000BASE-T Ethernet, RJ-45
 - Static or DHCP IP address
- 10-GbE output media: SR fiber, LR fiber, or twinax copper patch cables

ORDERING INFORMATION

- DLSR3-1U-2E4X-01
 - Two L-band inputs
 - Four 10-GbE outputs
- DLSR3-1U-4E8X-01 (coming soon)
 - Four L-band inputs
 - Eight 10-GbE outputs
- Units include two power supplies and power cords
- No-Cost configuration options include NFS or local boot modes and write protection on internal flash memories
- Rack slides and 10-GbE output media sold separately

Call for availability and custom configurations.

ADDRESS
101 N. Wilmot Rd., Ste. 101
Tucson, AZ 85711

ORDER LINE
520.519.3131
sales@rincon.com

TECH SUPPORT
520.519.3132
tech-line@rincon.com

FAX/WEB
520.519.3120
www.rincon.com

INFORMATION SUBJECT TO CHANGE WITHOUT NOTICE.
PRODUCTS ARE SUBJECT TO THE RESTRICTIONS OF THE ARMS EXPORT CONTROL ACT.
VERSION 1.1.

RINCON
RESEARCH
EMPLOYEE OWNED