



LPFE-IFXR

LPFE-IFXR SDR WITH DUAL IF TRANSCEIVER

- Wide input bandwidth enables IF digitization and direct-sampling applications from HF to 1 GHz
- Dual-channel, 14-bit ADCs, 200 MSPS to 500 MSPS
- Dual-channel, 16-bit DACs, 10 MSPS to 615 MSPS
- Ultra-low jitter integrated clock source, accepts external reference
- High-performance Xilinx Zynq Z7045 FPGA/ARM SoC
- Low-power IF-to-packets capability
- Many applications consume less than 15 W
- Write-protection controls for all non-volatile memory
- Capable of high-rate, high-order modulations (application not included)
 - FSK, BPSK, QPSK, SQPSK, 8PSK, QAM16 to QAM1024
- Accepts external time/frequency standards for geo-capable time-tagging
- Two rugged enclosures available, fan-cooled or conduction-cooled with IP-67 construction
- Flexible power options
 - 9 VDC to 57 VDC
 - Power of Ethernet (PoE) Type 2
- Flexible boot options: NFS, microSD card, or RAM-disk

RINCON RESEARCH CORPORATION'S (RRC) LPFE-IFXR is an extreme software-defined radio (xSDR), combining the xSDR LPFE DSP Base Card and xSDR IFXR in a compact chassis. The LPFE-IFXR is a high-performance DSP system, ideal for pairing with microwave receivers or direct-sampling HF signals. Its high-performance dual IF transceiver includes 14 bit, 500 MSPS ADCs and 16 bit, 615 MSPS DACs. This mezzanine card includes filters and amplifiers to simplify interfacing with external receivers and antennas.

RRC'S MOUNTAINBRIK™ APPLICATION may be used with the LPFE-IFXR to control the transceiver, view signal spectra, and record receiver data. Rincon's embedded Linux distribution, combined with the MountainBrik firmware, is capable of streaming signal data through the Ethernet interface at over 100 MByte/sec.

BLOCK DIAGRAM

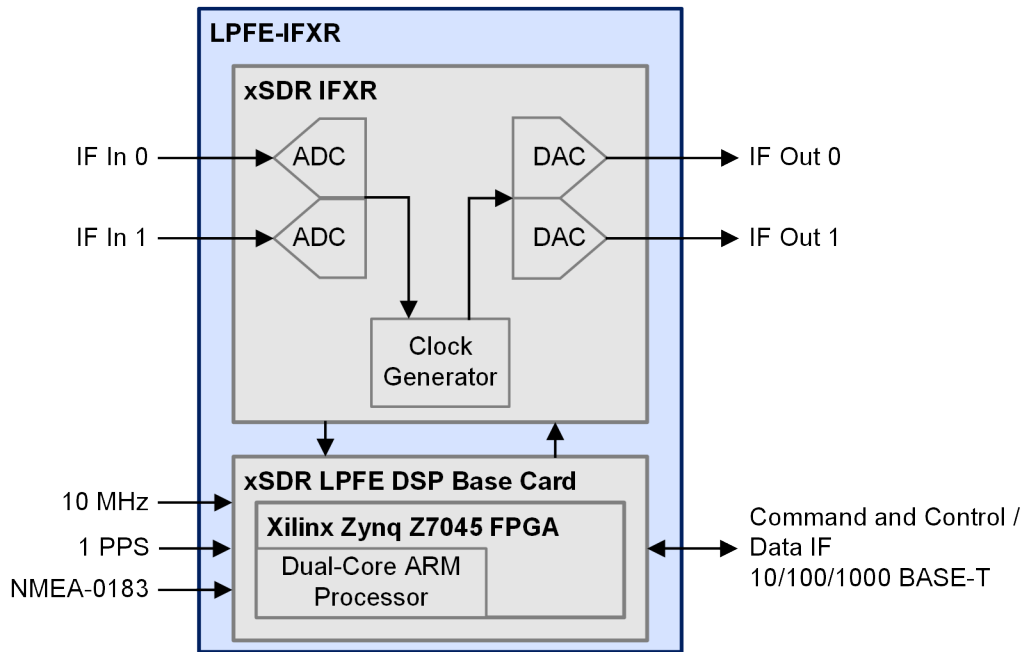

SPECIFICATIONS

ANALOG PERFORMANCE

- Analog Digitizer Card: xSDR IFXR, developed by RRC
- ADC: Dual, 14-bit, 200 MSPS to 500 MSPS
- ADC Full-Scale Input: -3 dBm
- ADC Two-Tone IMD: < -80 dBc (typ)
- DAC: Dual, 16-bit, 10 MSPS to 615 MSPS
- DAC Two-Tone IMD: > 65 dB (typ)
- Filtering: Switchable low-pass filters.
 - ADC: 220 MHz
 - DAC: 290 MHz

DIGITAL SPECIFICATIONS

- DSP Base Card: xSDR LPFE DSP Base Card, developed by RRC
- SoC: Xilinx Zynq Z7045 standard, Z7030 and Z7035 also available
- Memory: DDR3-1066
 - FPGA attached: 2 GBytes
 - ARM attached: 512 Mbytes
- I/O: 10/100/1000BASE-T Ethernet, USB 2.0 OTG
 - UARTs: USB and RS-232
- Timing Signals: 1 PPS and 10 MHz connectors, SMA, DC IRIG-B, U.FL
- OS: RRC's embedded Linux distribution

PHYSICAL

- Dimensions:
 - Fan-Cooled: 5.45" x 5.00" x 1.50", 35.5 oz.
 - Conduction-Cooled: 10.00" x 3.50" x 2.46", 62.4 oz.

ADDRESS

101 N. Wilmot Rd., Ste. 101
Tucson, AZ 85711

ORDER LINE

520.519.3131
sales@rincon.com

TECH SUPPORT

520.519.3132
tech-line@rincon.com

FAX/WEB

520.519.3120
www.rincon.com